



FEATURES

- Support for CCD and CMOS image sensors
- 4 AFE channels
- 1.8 V analog and digital core supply voltage
- Serial data output with reduced range LVDS outputs
- Differential analog inputs
- CDS or SHA configuration (CDS bypass) with -3 dB, 0 dB, +3 dB, and +6 dB gain
- 6 dB to 42 dB, 10-bit variable gain amplifier (VGA)
- 14-bit, 72 MHz analog-to-digital converter (ADC)
- Black level clamp with variable level control
- Precision Timing core with 220 ps resolution @ 72 MHz

APPLICATIONS

- Digital video cameras
- Digital still cameras
- Medical Imaging
- High speed industrial cameras

GENERAL DESCRIPTION

The ADDI7004 is a highly integrated, quad-channel, HD image signal processor for high speed imaging applications. Each channel is specified at pixel rates of up to 72 MHz and consists of a complete analog front end (AFE) with ADC conversion. The Precision Timing™ core allows adjustment of the correlated double sampler (CDS) and sample-and-hold amplifier (SHA) clocks with 220 ps resolution at 72 MHz operation. The ADDI7004 also contains a reduced range low voltage differential signaling (LVDS) interface for the dual-channel data outputs.

Each analog front end includes black level clamping, a CDS/SHA, a VGA, and a 72 MHz, 14-bit analog-to-digital converter (ADC). Operation is programmed using a 3-wire serial interface.

Packaged in a space-saving, 6 mm × 6 mm, 76-ball BGA, the ADDI7004 is specified over an operating temperature range of -25°C to +85°C.

FUNCTIONAL BLOCK DIAGRAM

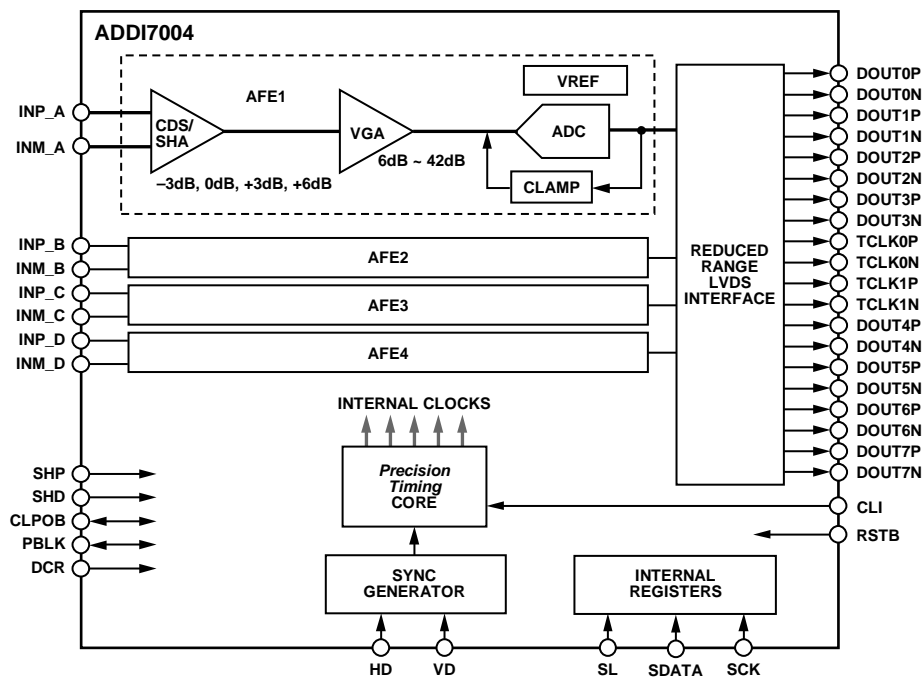

NOTES
1. THE CIRCUITRY FOR AFE1 TO AFE4 IS IDENTICAL.

Figure 1.

For more information on the ADDI7004, email Analog Devices, Inc., at afe.ccd@analog.com.

Rev. SpB

Information furnished by Analog Devices is believed to be accurate and reliable. However, no responsibility is assumed by Analog Devices for its use, nor for any infringements of patents or other rights of third parties that may result from its use. Specifications subject to change without notice. No license is granted by implication or otherwise under any patent or patent rights of Analog Devices. Trademarks and registered trademarks are the property of their respective owners.

ADDI7004

NOTES